

Showerlite Range

Domestic Range

SL/SLK 100MM 120MM & 150MM



- The Manrose Showerlite is a distinctive Showerlite which is incorporated into a circular diffuser, suitable for showers and bathrooms. Now available in 100mm (4"), 120mm (5") and 150mm (6") versions.
- The Showerlite can be used within the splash area of the shower or bath and is powered by a SELV remote safety isolating transformer.
- The Showerlite is suitable for any 100mm (4"), 120mm (5") and 150mm (6") in-line system such as the Manrose SF/ID range of in-line axial fans or the CFD/MAN range of in-line centrifugal fans.
- Available in two colours white, and chrome, the Manrose Showerlite will enhance any shower or bathroom providing a rich warm glow of soft light.
- The Showerlite is available separately in boxed carton packaging or in blister packs with or without transformer. They are also available in a blister fan kit pack. Each pack is supplied complete with fan (available with or without timer), Showerlite unit, transformer, one length of PVC flexible ducting, external wall grille, fixing screws, plugs and straps.
- A centrifugal in-line fan kit is now available for longer ducting runs.



Technical Details

Cat. No. Product type

Boxed Cartons

SL-W	Showerlite white fitting
SL-C	Showerlite chrome fitting
T1250W	Transformer

Showerlite In-Line Axial Extractor Packs Blister Packaging

SLKSC	Showerlite fan kit, standard model chrome and white fitting
SLKTC	Showerlite fan kit, timer model chrome and white fitting
SL-120SC	Showerlite fan kit, standard model chrome and white fitting
SL-120TC	Showerlite fan kit, timer model chrome and white fitting
SL-150SC	Showerlite fan kit, standard model chrome and white fitting
SL-150TC	Showerlite fan kit, timer model chrome and white fitting

Centrifugal Packs Boxed Packaging

SLCFDSC	Showerlite centrifugal fan kit, standard model chrome and white fitting
SLCFDTC	Showerlite centrifugal fan kit, timer model chrome and white fitting

Dimensions (mm)

PRODUCT	AØ	B	CØ
SL-W/C	140	74	98
SL120	170	74	118
SL150	200	74	148

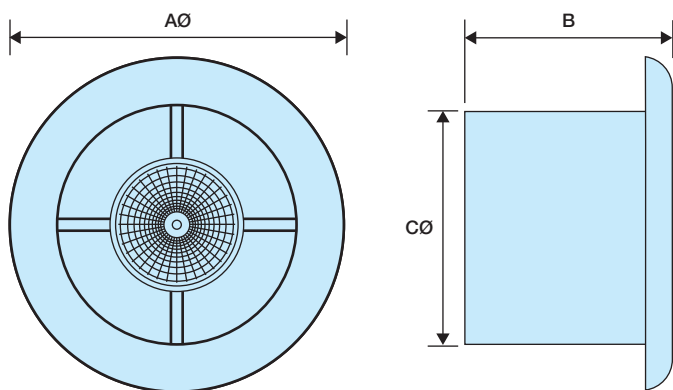

Packaging

Boxed in outers of 5. For packaging dimensions, contact our technical department.

Installation

Designed to be ceiling mounted through 102mm (4") diameter flexible ducting or rigid pipes.

Electrical

12 volt 35W dichroic 5.3 sealed lamp. Powered by a transformer T1250W. Input, AC. Output, 12 volt AC. 50 VA.

Construction

All plastic components are moulded in high temperature VO rated thermoplastics.

Typical Installation

