

320mm Inspection Chamber

Features & Benefits

320mm Inspection Chamber	
 <p>320mm DIA Chamber Base</p> <ul style="list-style-type: none">- The chamber base allows for multiple connection variations in direction to any 110mm drainage layout.- Supplied with two easy fit bungs to block off unused outlets.- Total depth can be up to 0.6m using R320.	 <p>320mm DIA Chamber Riser</p> <ul style="list-style-type: none">- Ribbed design on Riser increases product durability.
 <p>320mm DIA Round Cover & Frame</p> <ul style="list-style-type: none">- Ideal for tarmac, grass or gravel areas subject to pedestrian footfall only.- 1.5kn load rating classification.- Enhanced slip resistant tread pattern.	 <p>320mm DIA Square Cover & Frame</p> <ul style="list-style-type: none">- Ideal for paved areas subject to pedestrian footfall only.- 1.5kn load rating classification.- Enhanced slip resistant tread pattern.



■ Cover

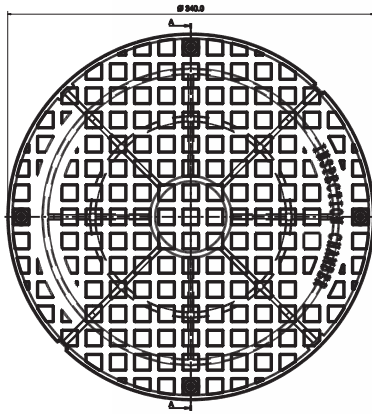

■ Riser

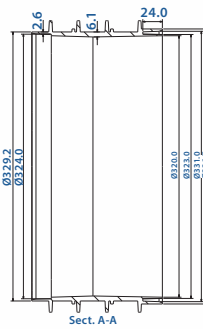
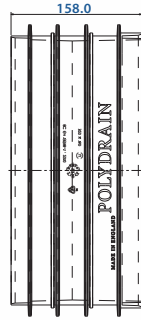
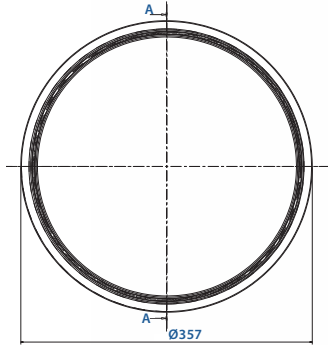

■ Three Inlet Base

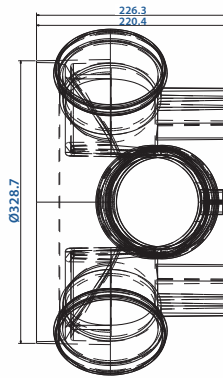
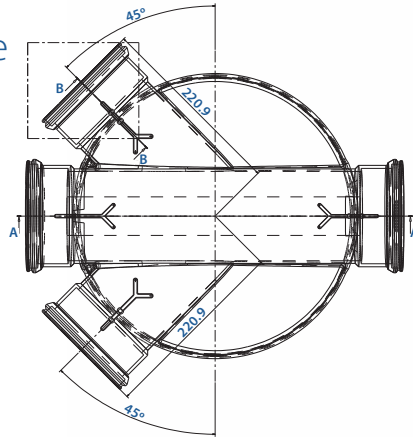

320mm Inspection Chamber

Dimensional Guide



320mm DIA Chamber Base

Channel Size 110mm
Code MB320



320mm DIA Chamber Riser

Channel Size 110mm
Depth
Code R320



320mm DIA Round Cover & Frame

DIA 320mm
Code RCF320



320mm DIA Square Cover & Frame

DIA 320mm
Code SCF320